

The Prediction of Solar Radiation for Five Meteorological Stations in Libya Using Adaptive Neuro-Fuzzy Inference System (ANFIS)

Muna A. Alzukrah¹ and Yosof M. Khalifa²

¹Department of Civil Engineering, Higher Institute for General Vocations, Agdabia-Libya.

²Center of Solar Energy Research and Studies, Tripoli-Libya.

e-mail: ¹ Makram84me@gmail.com, ² y.m.a.khalifa@csers.ly

Abstract: The prediction of solar radiation is very important tool in climatology, hydrology and energy applications, as it permits estimating solar data for locations where measurements are not available. In this paper, an adaptive neuro-fuzzy inference system (ANFIS) is presented to predict the monthly global solar radiation on a horizontal surface in Libya. The real meteorological solar radiation data from 5 stations for the period of 1982 - 2009 with different latitudes and longitudes were used in the current study. The data set is divided into two subsets; the first is used for training and the latter is used for testing the model. (ANFIS) combines fuzzy logic and neural network techniques that are used in order to gain more efficiency. The statistical performance parameters such as root mean square error (RMSE), mean absolute percentage error (MAPE) and the coefficient of efficiency (E) were calculated to check the adequacy of the model. On the basis of coefficient of efficiency, as well as the scatter diagrams and the error modes, the predicted results indicate that the neuro-fuzzy model gives reasonable results: accuracy of about 92% - 96% and the RMSE ranges between 0.22 - 0.35 kW.hr/m²/day.

استنباط الإشعاع الشمسي لعدد من المحطات الأرصادية في ليبيا باستخدام الأنظمة العصبية الضبابية القابلة للتكيف

منى الزكرة¹ و يوسف خليفة²

¹ قسم الهندسة المدنية، المعهد العالي للمهن الشاملة، اجدابيا - ليبيا

² مركز بحوث ودراسات الطاقة الشمسية، طرابلس - ليبيا

ملخص: إن التنبؤ بالإشعاع الشمسي من الأدوات المهمة جدا في تطبيقات علم المناخ والهيدرولوجيا والطاقة، كما أنه يسمح بتقدير بيانات الإشعاع الشمسي للمواقع التي لا تتوفر فيها قياسات لتلك البيانات. تستعرض هذه الورقة استخدام الأنظمة العصبية الضبابية

القابلة للتكيف (ANFIS) للتنبؤ بالمتوسطات الشهرية للإشعاع الشمسي على السطح الأفقي في عدد من المحطات الارصادية في ليبيا. استخدمت بيانات مفاصة للإشعاع الشمسي على المستوى الافقى للفترة من 1982-2009م لعدد خمس محطات ارسادية ولدوائر عرض وخطوط طول مختلفة. قسمت بيانات الاشعاع الشمسي الى قسمين رئيسيين، استخدم الأول للتدريب والآخر لاختبار النموذج، حيث إن الأنظمة العصبية الضبابية القابلة للتكيف تجمع بين تقنيات ما يعرف بالشبكة العصبية والمنطق الضبابي المستخدمين للحصول على كفاءة عالية. تم حساب أداء المتغيرات الإحصائية من خلال حساب كل من جذر متوسط مربع الخطأ، والمتوسط المطلق لنسبة الخطأ و معامل الكفاءة بهدف التحقق من كفاءة أداء النموذج. بناء على معامل الكفاءة فضلا عن الرسومات البيانية المبعثرة ووسائل الخطأ فقد أوضحت النتائج أن الأنظمة العصبية الضبابية القابلة للتكيف قد اعطت نتائج جيدة حيث تراوح معامل الكفاءة بين 92-96% و تراوح جذر متوسط مربع الخطأ التربيعي ما بين 0.22 – 0.35 كيلووات.ساعة/متر²/ يوم.

Keywords: Adaptive Neuro-Fuzzy System, Fuzzy logic, Neural Network, Monthly Global Solar Radiation, Root Mean Square Error.

1. INTRODUCTION

Solar radiation is the driving force for hydrological cycle. It is one of the most important factors used in estimation of evaporation (E) and evapotranspiration (ET), where loss of water through evaporation is a major consideration in the design management of water supply reservoirs and water supply. There is lack of solar radiation measurements in Libya for practical problems because it requires sensitive solar sensors which are expensive and not available in most Libyan meteorological stations. Thus, prediction of solar radiation plays very important role in climate impact assessments of agricultural, water system management, design of the renewable and solar energy systems. The strategic location of Libya in the center of North Africa with vast area which is mostly desert and its geographical position favors the development and utilization of solar energy. This makes it necessary to study and estimate the solar radiation at several locations distributed all over the country.

The ANFIS modeling strategy is widely used in the applications or systems that involve uncertainty or imprecision in the measurements and definitions of the variables constituting the system's behavior. In other words, it is widely accepted as a promising tool because it uses linguistic terms, and is able to deal with nonlinear problems and can perform predictions at high speed. In the last few decades, ANFIS has been successfully applied to various problems. Dakhil, et al. (2000) studied solar radiation on horizontal surface in Libya over the

period 1981-1987. The solar radiation is estimated by using empirical equations. Bannani, et al. (2005) estimated the monthly average global radiation, where regression equations for eleven stations in Libya were fitted, using monthly average hours of sunshine duration as predictors. Iqdour and Zeroual (2006) used the Takagi-Sugeno fuzzy systems for modeling daily global solar radiation recorded in Dakhla, Morocco. The predicting results indicate that the Takagi-Sugeno fuzzy model gives a good accuracy of approximately 96% and a root mean square error lower than 6%. Also Mellit et al. (2008) proposed a new model based on neuro-fuzzy for predicting the sequences of monthly clearness index and applied it for generating solar radiation which has been used for the sizing of a PV system. The proposed model has been used for estimating the daily solar radiation. Senkal and Kuleli (2009) also used artificial neural networks for the estimation of solar radiation in Turkey.

Meteorological and geographical data (latitude, longitude, altitude, month, mean diffuse radiation and mean beam radiation) are used in the input layer of the network and Solar radiation is the output. In 2011, Rahoma, et al applied a neuro-fuzzy technique for the prediction of solar radiation to Helwan, Egypt. They used the daily data and showed that an ANFIS model gives a good accuracy of approximately 96% and a root mean square error lower than 6%. Recently, Sumithira, et al (2012) developed an adaptive neuro-fuzzy inference system (ANFIS) to predict monthly global solar radiation (MGSR) in Tamilnadu, India.

In this paper, an attempt has been made for implementing the ANFIS model to predict monthly global solar radiation data for the period of 1982-2009 from 5 meteorological stations in Libya.

2. METHODOLOGY

An Adaptive Neuro Fuzzy Inference System (ANFIS) is a kind of artificial neural network that is based on Takagi– Sugeno fuzzy inference systems ANFIS concatenates the fundamentals of Neural Network and the Fuzzy logic. The ANFIS architecture is proposed by Jang (1993) and is developed based on the theory of fuzzy set and fuzzy logic. It is a combination of two intelligence systems, namely ANN system and FIS system in such a way that the ANN learning algorithm is used to determine the parameters of the FIS. ANN is a non-linear statistical data-modeling tool, which can capture and model any input-output relationship (or can learn detect complex patterns in data). FIS (involves membership function (mf), fuzzy logic operator and if-then-rules) is the process of formulating the mapping from a given input to an output using fuzzy logic (Patel, 2014). Each fuzzy system contains three main parts: fuzzification, inference, and defuzzification. Basically a fuzzy inference is composed of five functional blocks:

- Input characteristics to input membership functions,

- Input membership function to rules,
- Rules to a set of output characteristics,
- Output characteristics to output membership functions.
- The output membership function to a single valued output, or a decision associated with the output.

For simplicity, a fuzzy inference system has two inputs x and y one output is assumed. For a first-order Sugeno fuzzy model, a common rule set with two fuzzy IF-THEN rules are defined as:

$$\text{Rule 1: If } x_1 \text{ is } A_1 \text{ and } x_2 \text{ is } B_1, \text{ then } f_1 = a_1x_1 + b_1x_2 + c_1 \quad \dots\dots\dots (1)$$

$$\text{Rule 2: If } x_1 \text{ is } A_2 \text{ and } x_2 \text{ is } B_2, \text{ then } f_2 = a_2x_1 + b_2x_2 + c_2 \quad \dots\dots\dots (2)$$

Where: a_1, a_2 and b_1, b_2 are membership of input variables x and y which are parameters of the output function f_1 and f_2 .

A typical architecture of an ANFIS model with two input variables, in which a circle indicates a fixed node, whereas a square indicates an adaptive node, is shown in Figure 1. In this connections structure, there are input and output nodes, and in the hidden layers, there are nodes functioning as membership functions (MFs) and rules.

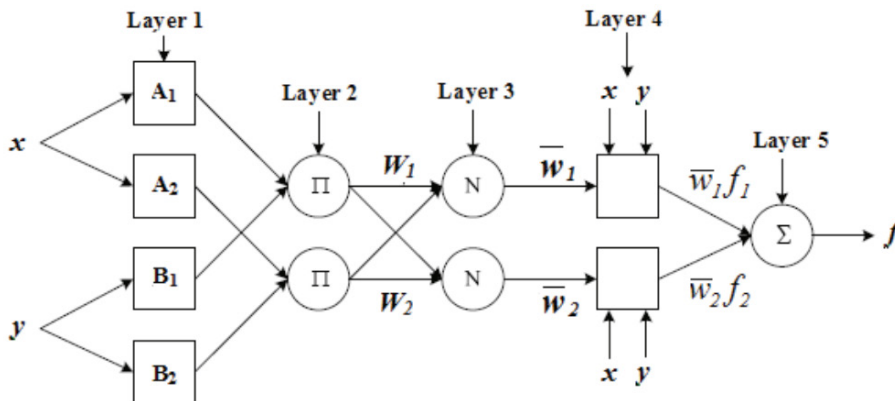

Figure (1). ANFIS architecture

3. THE STUDY AREA

Libya occupies a part of Northern Africa located between 20° to about 34° N latitude and between 10° to 25° E longitude. It has an important physical asset by its strategic location at the midpoint of Africa's Northern rim as shown in Figure 2. Total area of Libya is about 1.76 Million km²; it ranks fourth in area among all countries of Africa and fifteenth among all countries on earth. More than 95% of Libya is desert (El-Tantawi, 2005). The maximum global solar radiation over Libya ranges between 9.30 to 10.69 kW.hr/m²/day going from north to south. Also the yearly average values are 5.79 and 8.58 kW.hr/m²/day (El-Tantawi, 2005). The latitude, longitude and altitude of the five considered stations are presented in Table 1.

Table (1). Latitude, Longitude and Altitude of the stations under consideration (Dakhil et al., 2000)

Station	Latitude (N)	Longitude (E)	Altitude (m)
Benina	32.10	20.15	39
Ghat	26.07	10.15	699
Hun	29.13	15.95	265
Sabha	27.02	14.43	437
Tripoli	32.97	13.18	30

4. PREDICTIONS OF SOLAR RADIATION

4.1 Data Collection

In the current study, data used for training and testing the ANFIS models have been collected from the Libyan National Meteorological Center, Tripoli and from the Center for Solar Energy Research and Studies, Tripoli. The data are mainly monthly average for the in-situ observations of sunshine duration (SH) and solar radiation (SR). Table 2

displays statistical summary of SH and SR for the five stations under consideration.



Figure (2). Physical setting of the study area.

Table (2). The statistical information for all stations under consideration

Variables	*SH (hr)	**SR (kW.hr/m ² /day)
Σ	15606.47	9301.32
Mean	9.29	5.45
Variance (σ ²)	3.80	2.86
Standard deviation (σ)	1.95	1.69
Skewness coefficient (S.C)	-0.31	-0.23
Coeff. of variation (C.V)	0.21	0.30
Correlation coefficient (r)	0.85	

*SH is the Sunshine Hours (hr) and **SR is the Solar Radiation (kW.hr/m²/day).

4.2 Training of the ANFIS Models and Application

In the training and testing phases of the proposed models, data sets of 1500 values from 1982

to 2006 and 180 values from 2007 to 2009 have been used, respectively. Firstly, the model is constructed by using 1 input (i.e. sunshine duration) which was split into six membership functions. Then the ANFIS model was trained for 3 inputs with four and six membership functions and one output. Finally,

to predict monthly solar radiation; the year, month, latitude, longitude and sunshine duration were used as inputs to the model. The number of membership functions and the linguistic variable of the neuro-fuzzy are presented in Table 3.

Table (3). The linguistic variable for the input for the neuro-fuzzy membership functions for all stations

The variable	The linguistic variable	
	Name	Symbol
Years	First Group	G1
Ranges of data	Second Group	G2
1982 to 2009	Third Group	G3
	Fourth Group	G4
Months	First Season	S1
Ranges of data	Second Season	S2
1 to 12	Third Season	S3
	Fourth Season	S4
Latitude (N)	Small	S
Ranges of data	Medium	M
24.95 to 32.54	High	H
Longitude (E)	Small	S
Ranges of data	Medium	M
10.17 to 20.16	High	H
Sunshine duration (hr)	Very Short	VSh
Ranges of data	Short	Sh
2.30 to 13.00	Medium	M
	High Medium	HM
	Long	L

Figures 3, 4 and 5 demonstrate the membership function of the input data with 1 input, the membership function of the input data with 3 inputs and the membership function of the input data of 5 inputs respectively. As we can see from the figures that the shape of HM membership function, red colored line, can be any appropriate function that are continuous and piecewise differentiable such as Gaussian, general bell shaped, such shapes were chosen by MATLAB functions used for such calculations.

4.3 Performance Indicators

Basis of the following statistical error tests: the mean absolute percentage error (MAPE), root mean square error (RMSE) and the coefficient of efficiency (E) tests were applied as they are the most commonly used techniques in comparing the models of solar radiation estimations. They are defined below as:

A. Mean absolute percentage error (MAPE):

$$MAPE = \frac{\sum_{i=1}^n \left| \frac{x_i - y_i}{y_i} \right|}{n} * 100 \dots\dots\dots (3)$$

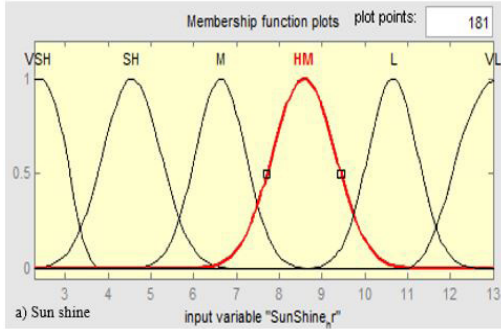

Figure (3). The membership function of the input data, (ANFIS - 1 input)

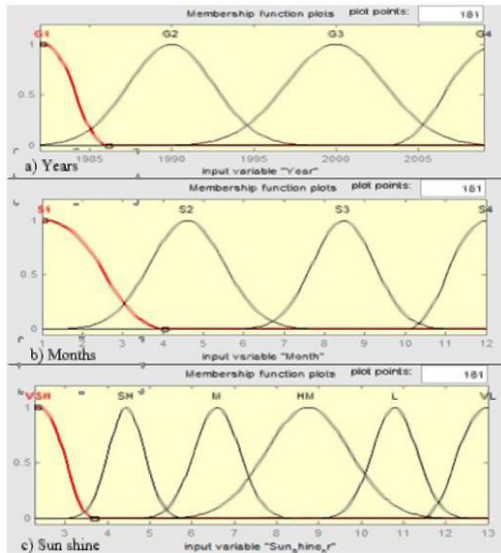

Figure (4). The membership function of the input data, (ANFIS - 3 inputs).

B. Root mean square error (RMSE):

$$RMSE = \sqrt{\frac{\sum_{i=1}^n (x_i - y_i)^2}{n}} \dots\dots\dots (4)$$

C. Nash-Sutcliffe efficiency (coefficient of efficiency):

The efficiency factor (E) proposed by Nash and Sutcliffe (1970) is defined as follows:

$$E = 1 - \left(\frac{\sum_{i=1}^n (x_i - y_i)^2}{\sum_{i=1}^n (y_i - \bar{y})^2} \right) \dots\dots\dots (5)$$

Where: x_i the predicted data; y_i the observed data and n the number of data observed.

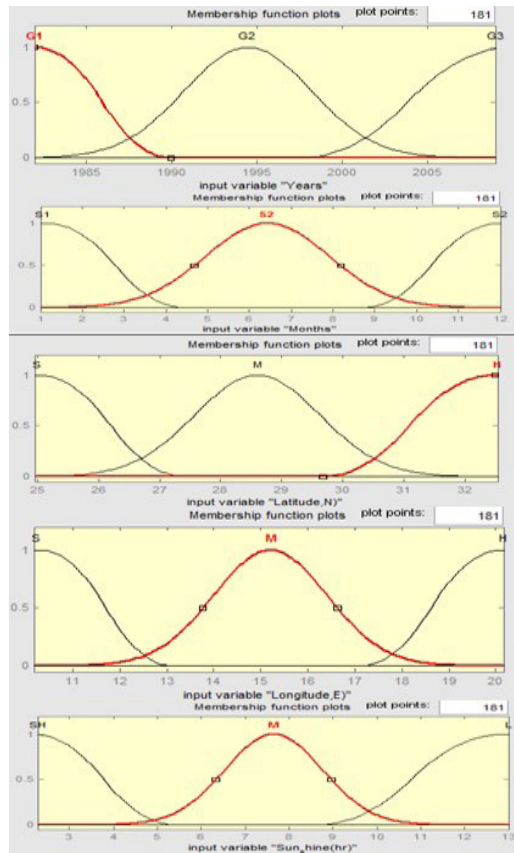

Figure (5). The membership function of the input data, (ANFIS - 5 inputs)

5. RESULTS AND DISCUSSION

The ANFIS system was applied to the available data, the model is trained for many scenarios with different inputs. Membership functions of different variables are selected as Gaussian shapes. The Performance of each model was studied by evaluating its statistical performance. The three most widely used statistical indicators in estimation models are the coefficient of determination E, the root mean square error (RMSE) and the mean absolute percentage error (MAPE). On the basis of

correlation coefficients and the efficiency factor (E) as well as the scatter diagrams, the ANFIS models appear successful and yield reliable results. It was found out that using more input variables in the training phase leads to enhance the performance of the models. That is the ANFIS with 5 inputs variable produces good results in comparison to the model with 1 input variable. The MAPE decreases and the E increases as the number of input variables increases. For example, the model with the latitude, longitude, year, month and sun shine hours as inputs gives

MAPE (3.76%) and E (0.96) whereas the model with the sunshine hours as input gives MAPE (13.82%) and E (0.74). In the training phase the coefficient of efficiency E was found to vary between 0.74-0.96 for the monthly solar radiation during 1982 to 2006 for the 5 stations. However, in the testing phase the coefficient of efficiency E ranged between 0.70 – 0.92 for the monthly solar radiation during 2007 to 2009 for the 5 stations. The models statistical performances for all station are presented in Table 4.

Table (4). Models statistical performances

The statistical error	Period (1982-2006)			Period (2007-2009)		
	ANFIS	ANFIS	ANFIS	ANFIS	ANFIS	ANFIS
	1 input	3 inputs	5 inputs	1 input	3 inputs	5 inputs
MAPE %	13.82	5.77	3.76	12.98	8.18	9.54
RMSE (kW.hr/m2/day)	0.85	0.37	0.22	0.95	0.57	0.35
E %	74	95	96	70	89	92
Mean (kW.hr/m2/day)	5.49	5.49	5.12	5.58	5.75	5.56
σ (kW.hr/m2/day)	1.44	1.63	1.83	1.45	1.72	1.77

Figures 6, 7 and 8 show Scatter diagram of predicted and observed monthly solar radiation for ANFIS models. Figures 9, 10 and 11 show the $\pm 95\%$ confidence interval for the predicted solar radiation data for ANFIS models.

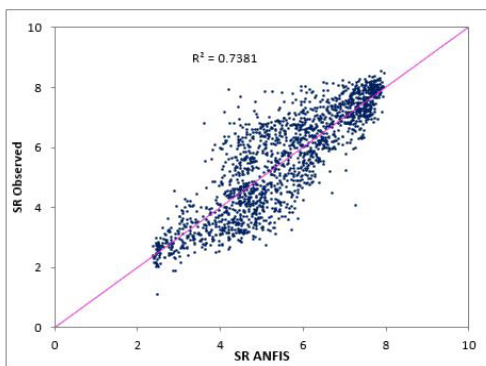

Figure (6). Scatter diagram of predicted and observed monthly solar radiation for all stations, (ANFIS – 1 input).

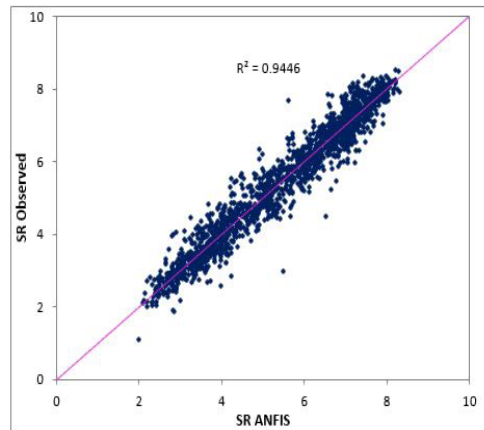

Figure (7). Scatter diagram of predicted and observed monthly solar radiation for all stations, (ANFIS – 3 inputs).

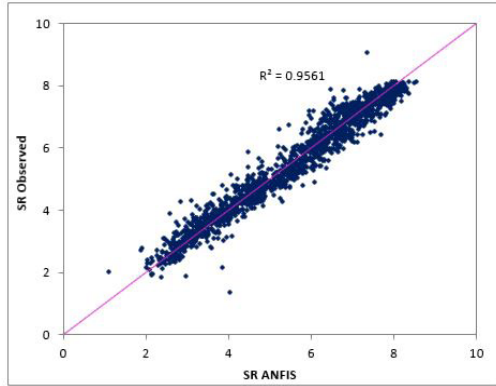

Figure (8). Scatter diagram of predicted and observed monthly solar radiation for all stations, (ANFIS - 5 inputs).

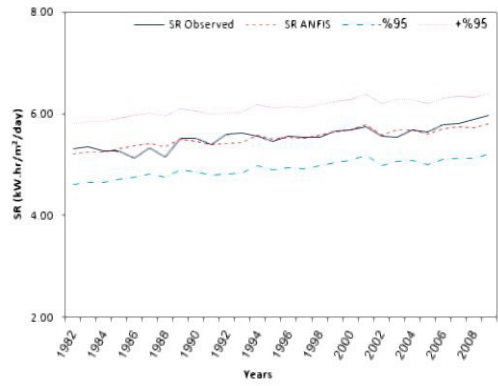

Figure (11). The $\pm 95\%$ confidence interval for the predicted solar radiation data for all stations, (ANFIS - 5 inputs)

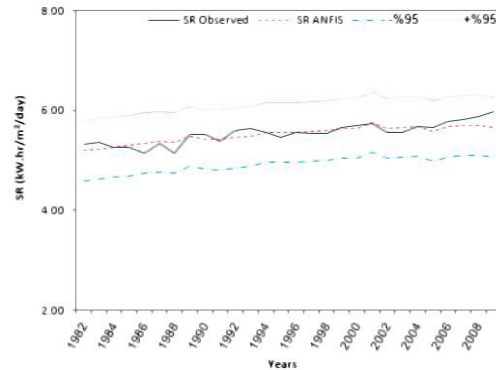

Figure (9). The $\pm 95\%$ confidence interval for the predicted solar radiation data for all stations, (ANFIS - 1 input).

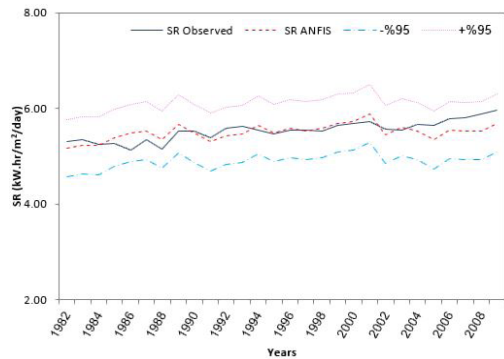

Figure (10). $\pm 95\%$ confidence interval for the predicted solar radiation data for all stations, (ANFIS - 3 inputs)

6. CONCLUSION

The proposed ANFIS model to predict the monthly global solar radiation is a successful tool and suitable for solar radiation application. Also, it is possible to generate this data for any remote regions. The values of performance parameters such as root mean square error (RMSE), the coefficient of efficiency (E) and the mean absolute percentage error (MAPE) presented in this paper are very satisfying. The ANFIS models show promising results for evaluating monthly global solar radiation in any region. The findings demonstrate the predicting capability of ANFIS models and their compatibility for any region with varying climatic conditions. Furthermore, it is suitable for a place where a network of monitoring stations has not been setup. In the future works, some additional inputs may be employed for solar radiation prediction and dividing the data to seasonal data may be more useful. In addition, authors recommend using hourly data instead of mean monthly data for the predictions of solar irradiation. This will be done in another paper in future.

REFERENCES

[1]. Azar, (2010), " Adaptive Neuro-Fuzzy Systems".
Electrical Communication & Electronics

- Systems Engineering department, Modern Science and Arts University (MSA), Egypt.
- [2]. Bannani, F. K., Sharif, T. A. & Ben-Khalifa, A. O. R. (2005), "Estimation of monthly average solar radiation in Libya", *Theoretical and Applied Climatology*. Vol. 83, pp. 211–215.
- [3]. Dakhil, M., Hassan, Y. & Alemam, M. (2000), "Study and analysis of solar radiation on horizontal surface in Libya", *Energy and Life*, Vol. 13, pp. 46–52.
- [4]. El-Tantawi, (2005). *Climate Change in Libya and Desertification of Jifara Plain Using Geographical Information System and Remote Sensing Techniques*, Graduate Faculty of The University of Georgia Gutenberg.
- [5]. Iqdour, R. & Zeroual, A. (2006), "A rule based for the prediction of solar radiation", *Revue des Energies Renouvelables*, Vol. 9, No. 2, pp. 113–120.
- [6]. Mellit, A., Kalogirou, S. A., Shaari, S., Salhi, H. & Hadj Arab, A. (2008), "Methodology for predicting sequences of mean monthly clearness index and daily solar radiation data in remote areas: Application for sizing a stand-alone PV system", *Renewable Energy*, Vol. 33, pp. 1570–1590.
- [7]. Mubiru, J. & Banda, E.J.K.B. (2008), "Estimation of monthly average daily global solar irradiation using artificial neural networks", *Solar Energy*, Vol. 82, pp. 181–187.
- [8]. Patel, J. & Parekh, F. (2014), "Forecasting Rainfall Using Adaptive Neuro – Fuzzy Inference System (ANFIS) " *International Journal of Application or Innovation in Engineering and Management*, Vol. 3, pp. 262–269.
- [9]. Rahoma, W. A., Rahoma, U. A & Hassan, A. H. (2011), "Application of Neuro-Fuzzy Techniques for Solar Radiation", *J. Computer Science*, Vol. 7, No. 10, pp. 1605–1611.
- [10]. Şen, Z. (2008), "Solar energy fundamentals and modeling techniques ", Springer –Verlag London Limited, London.
- [11]. Senkal, O. & Kuleli, T. (2009), "Estimation of solar radiation over Turkey using artificial neural network and satellite data", *Applied Energy*, Vol. 86, pp. 1222–1228.
- [12]. Sumithira, T.R., A. & Ramesh Kumar, R. (2012), "An adaptive neuro-fuzzy inference system (ANFIS) based Prediction of Solar Radiation: A Case study ", *Journal of Applied Sciences Research*, Vol. 8, pp. 346–351.